

Cable Launch Male Connector (TSM P/N: 050-3055-001)

For Panel Mount Applications

Required Tools and Materials

Assembly Tool (TSM P/N 520-3303-001)

Removal Tool (TSM P/N 520-3303-002)

Assembly Block (TSM P/N 520-3303-004)

3/32" Hex Key

- 1 Removing channel to be replaced.** Insert the removal tool over the desired channel. Apply pressure inward while also turning the tool.

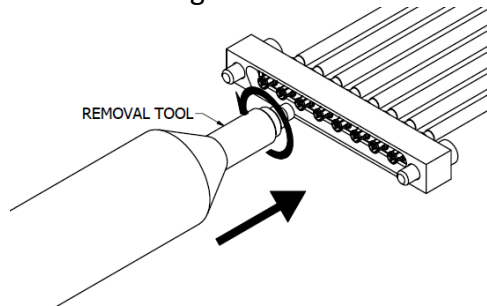
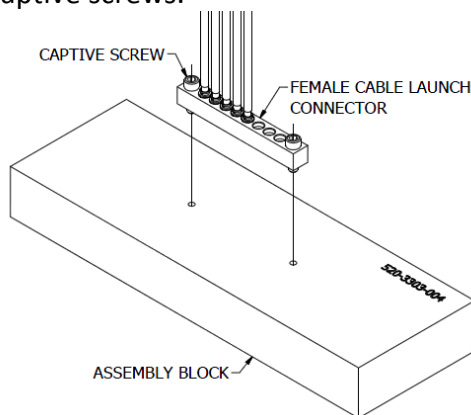

Figure 1

NOTE: There should be a click once tool has freed the retaining ring. At this point the channel should be loose and can be removed from the rear of the connector.

- 2 Mounting the connector to the assembly block.** Place the Mini-MultiMate connector onto the assembly block with the keying feature facing down. Using the 3/32" hex key secure the connector to the block by tightening the captive screws.



PES-2374 Rev B

Figure 2

- 3 Preparing channel for replacement.** Place the spare channel in the groove of the assembly tool so that the tool is resting on the flange of the SMPM connector.

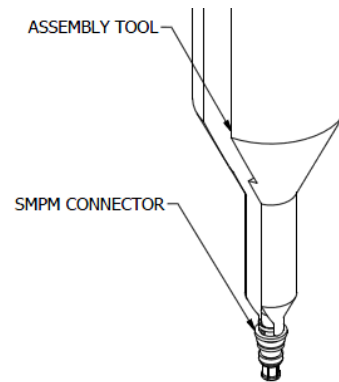

Figure 3

- 4 Installing replacement channel.** Place the replacement assembly with the assembly tool over the empty channel in the Mini-MultiMate connector. Begin to insert the cable applying light pressure downward. If the connector does not snap in begin to slightly rock the assembly tool while continuing to apply pressure downward.

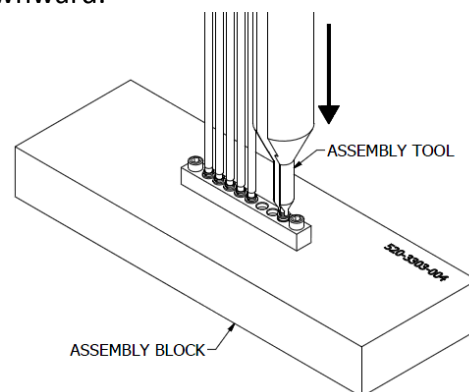

Figure 4

NOTE: DO NOT apply excessive pressure to insert the connector. The retaining rings on the SMPM connectors will be damaged if they are forced.

Cable Launch Male Connector (TSM P/N: 050-3055-001)

For Panel Mount Applications

Required Tools and Materials

Flat Head Screw Driver

1 Removing channel to be replaced.

Using a flat head screw driver loosen the lock nut. In order to fit into the slot in the lock nut the screw driver head dimensions should be .029" thick x .170" wide. Once the lock nut has been removed, the channel can be removed through the back of the Mini-MultiMate connector.

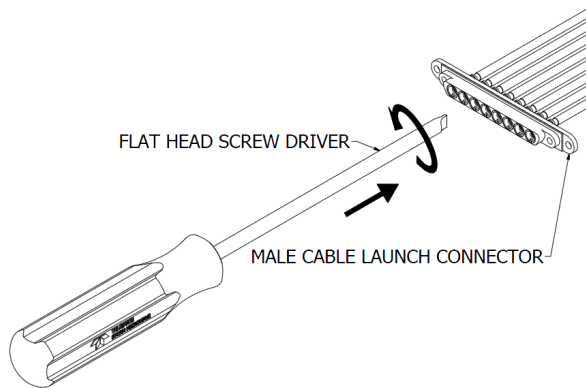

Figure 1

2 Installing replacement channels.

Remove the lock nut from the replacement channel and insert the cable assembly into the Mini-MultiMate connector from the rear. Install the lock nut from the front of the connector.

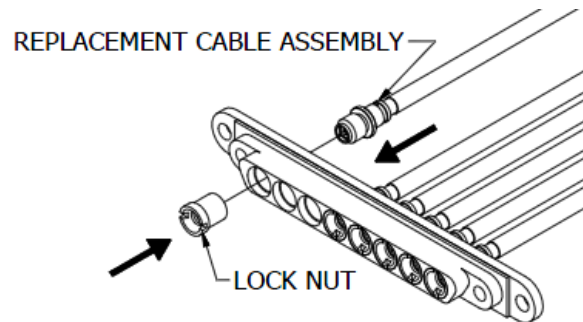

Figure 2

Tighten the lock nut using a flat head screw driver. Screw driver should have head dimensions as described in step 1.